

### Dimensions and weights:

Total length:	13.100 mm
Height:	4.600 mm
Width:	4.700 mm
Hopper width:	1.800 x 1.000 mm
Bale dimensions:	750 mm x 1.100 mm (length adjustable)
Machine weight:	approx. 28 Tons

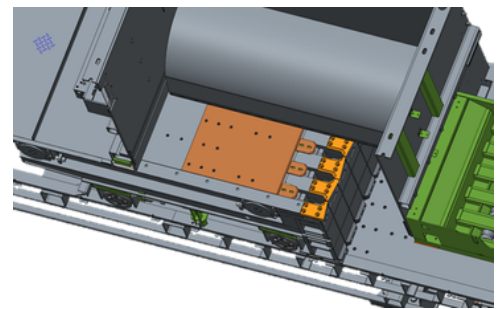

Closing plates (opened)

### Performance data:

Pressing force:	120 tons
Drive power:	2 x 45 kW
Bale weight:	550- 730 KG (depending on the material)

Throughput according to bulk density:	at 30 kg/m <sup>3</sup> - ca. 6.2 t/h
	at 50 kg/m <sup>3</sup> - ca. 9,8 t/h
	at 100 kg/m <sup>3</sup> - ca. 17,3 t/h

Twine tying:	5 fold vertical, wire 3 fold horizontal, wire
--------------	--

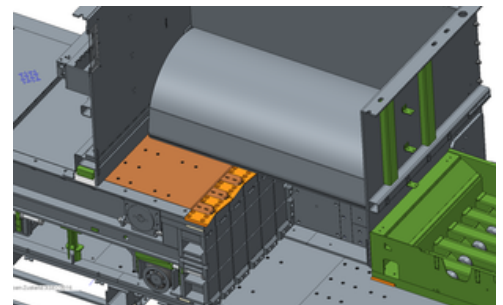

Closing plates (closed)

### Equipped with:

- Height-adjustable rollers on the press ram
- Closing plates above and below the ram
- Remote maintenance system
- Wear-resistant guiding rails
- PLC-Control system Siemens S7-300
- Cutting edge cleaner

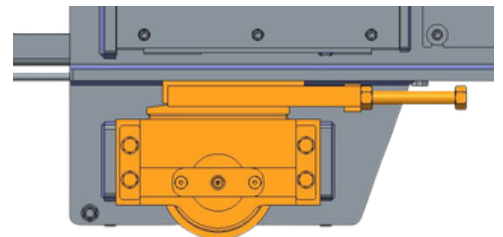

Height-adjustable rollers on the press ram

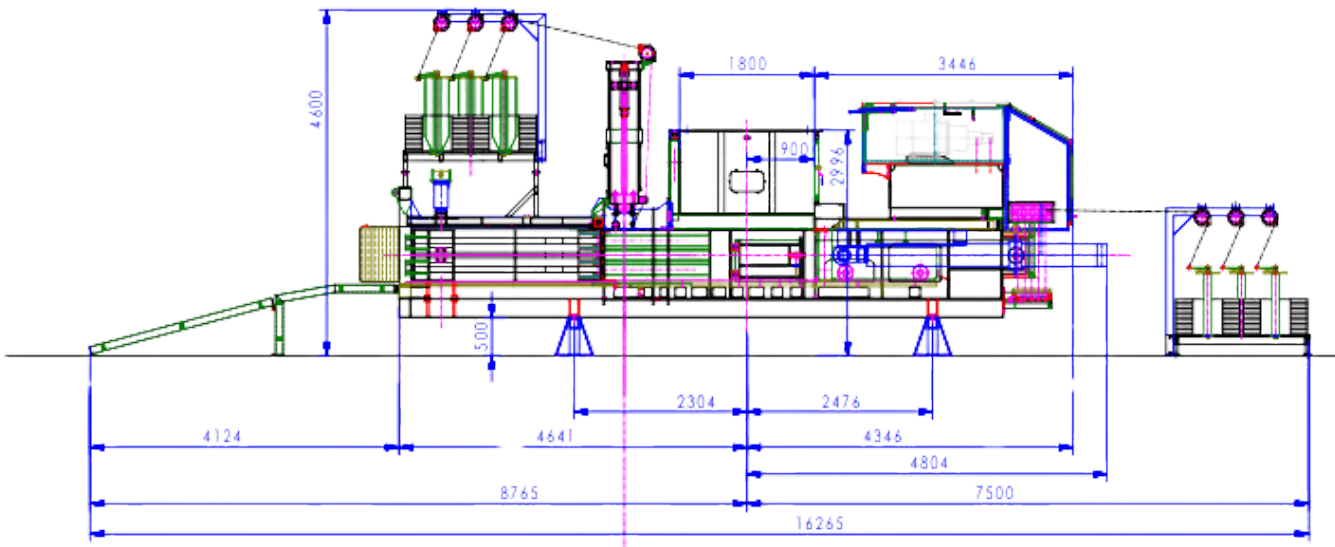

## Maße und Gewichte:

Länge:	13.100 mm
Höhe:	4.600 mm
Breite:	4.700 mm
Trichterbreite:	1.800 x 1.000 mm
Ballenabmessungen:	750 mm x 1.100 mm (länge einstellbar)
Maschinengewicht:	ca. 28 Tonnen

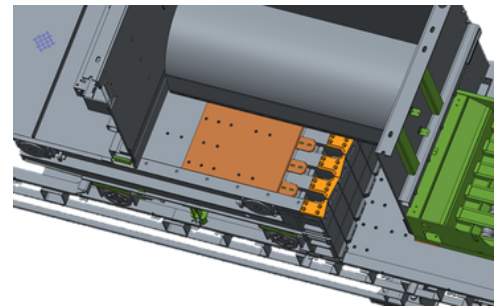

Kolbenschieber (geöffnet)

## Leistungsdaten:

Presskraft:	120 Tonnen
Antriebsleistung:	2 x 45 kW
Ballengewicht:	550- 730 KG (abhängig vom Material)

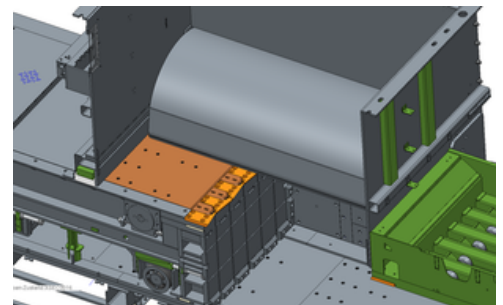

Kolbenschieber (geschlossen)

Durchsatz in abhängigkeit der Schüttdichte:	bei 30 kg/m <sup>3</sup> - ca. 6,2 t/h bei 50 kg/m <sup>3</sup> - ca. 9,8 t/h bei 100 kg/m <sup>3</sup> - ca. 17,3 t/h
--	--

Draht- Abbindung:	5-fach vertikal, Draht 3-fach horizontal, Draht
-------------------	--

## Ausgestattet mit:

- Höhenverstellbare Laufrollen am Pressschild
- Kolben-Boden-Schieber
- Fernwartung
- Verschleißfeste HARDOX-Laufschienen
- SPS-Steuerung Siemens S7-300
- Schneidkantenfreistampfer

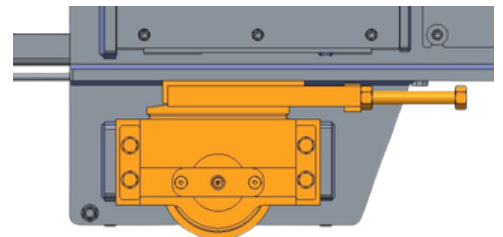

Höhenverstellbare Laufrollen am Pressschild