

### Dimensions and weights:

Total length:	9.255 mm
Height:	3.500 mm
Width:	2.500 mm
Hopper width:	1.440 x 1.100 mm
Bale dimensions:	750 mm x 1.100 mm (length adjustable)
Machine weight:	approx. 14 Tons

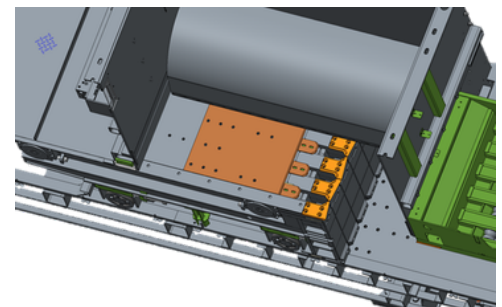

Closing plates (opened)

### Performance data:

Pressing force:	60 tons
Drive power:	2 x 22 kW
Bale weight:	250 - 500 KG (depending on the material)

Throughput according to bulk density:	at 30 kg/m <sup>3</sup> - ca. 3,0 t/h
	at 50 kg/m <sup>3</sup> - ca. 6,5 t/h
	at 100 kg/m <sup>3</sup> - ca. 9,0 t/h

Tying: 5 fold vertical, wire

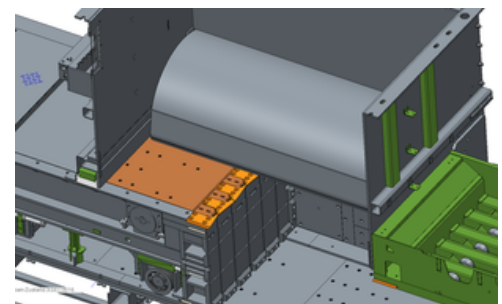

Closing plates (closed)

### Equipped with:

- Height-adjustable rollers on the press ram
- Closing plates above and below the ram
- Remote maintenance system
- Wear-resistant guiding rails
- Cutting edge cleaner

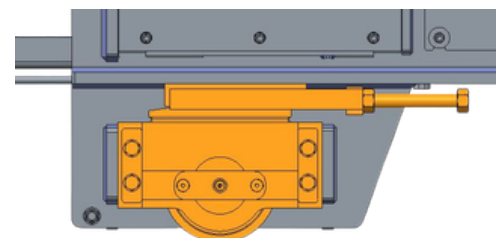

Height-adjustable rollers on the press ram

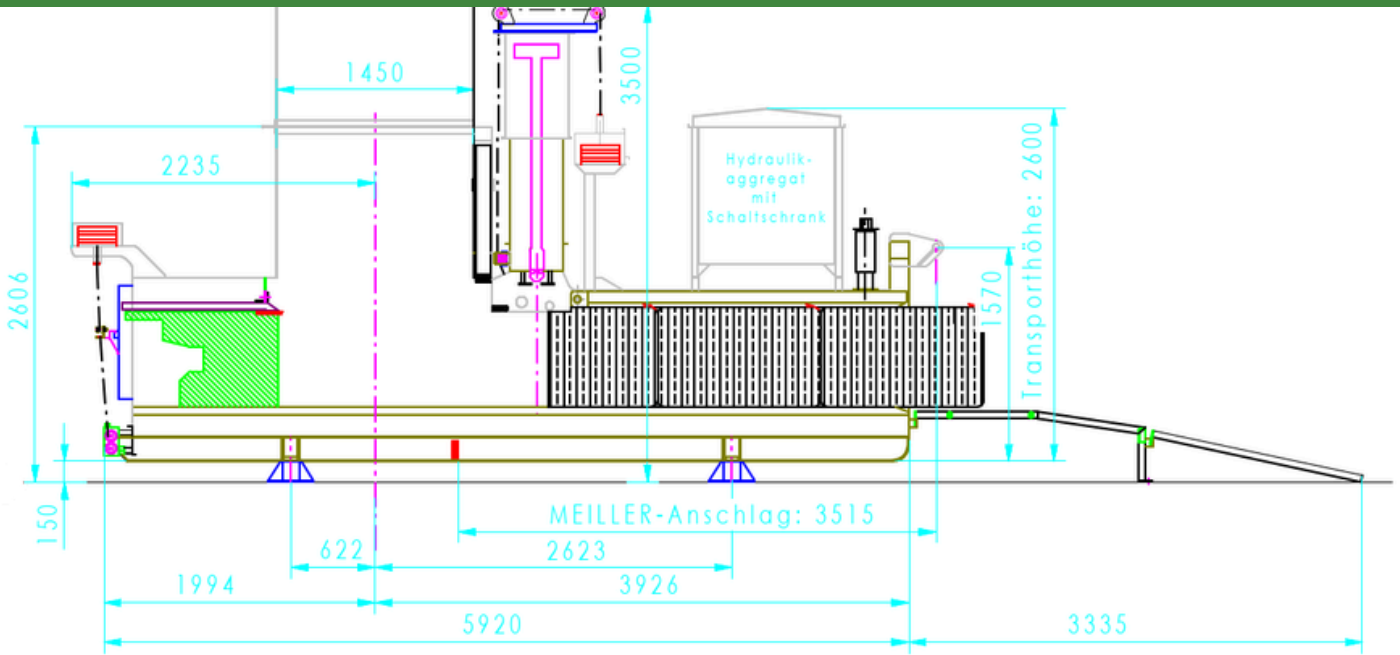

### Maße und Gewichte:

Länge:	9.255 mm
Höhe:	3.500mm
Breite:	2.500 mm
Trichterbreite:	1.440 x 1.100 mm
Ballenabmessungen:	750 mm x 1.100 mm (Länge einstellbar)
Maschinengewicht:	ca. 14 Tonnen

### Leistungsdaten:

Presskraft:	60 Tonnen
Antriebsleistung:	2 x 22 kW
Ballengewicht:	250 - 500 KG (abhängig vom Material)

Durchsatz in Abhängigkeit der Schüttdichte:	at 30 kg/m <sup>3</sup> - ca. 3,0 t/h at 50 kg/m <sup>3</sup> - ca. 6,5 t/h at 100 kg/m <sup>3</sup> - ca. 9,0 t/h
---	--

Abbindung: 5-fach vertikal, Draht

### Ausgestattet mit:

- Höhenverstellbare Laufrollen am Pressschild
- Kolben-Boden-Schieber
- Fernwartung
- MEILLER-Hakenaufnahme
- Schneidkantenfreistampfer

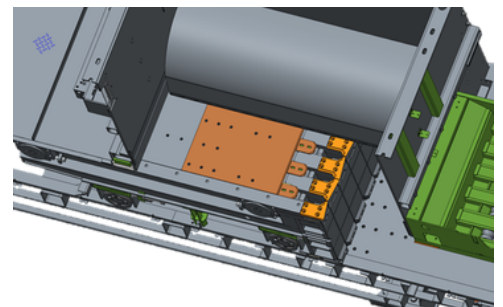

Kolbenschieber (geöffnet)

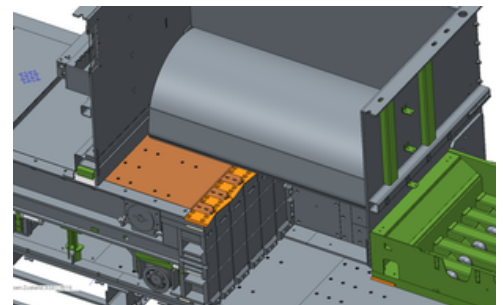

Kolbenschieber (geschlossen)

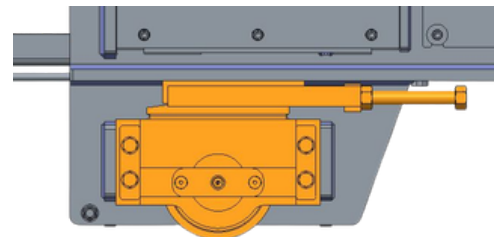

Höhenverstellbare Laufrollen am Pressschild